

SCHNITT A-A

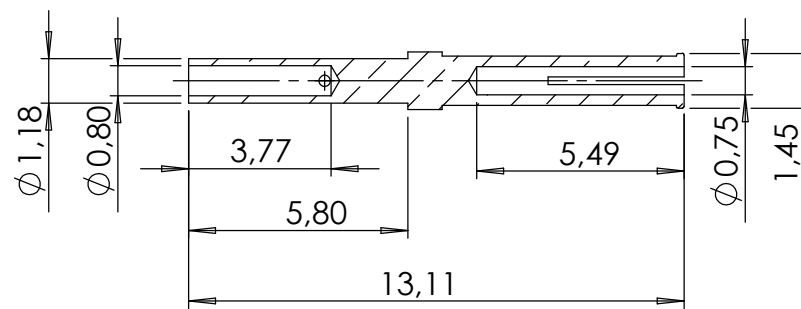

M 1:1

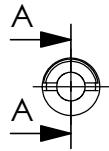
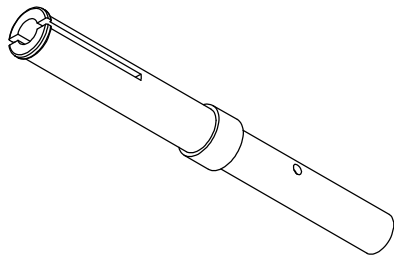

Bemerkungen (Remarks)				Freimaßtoleranz (Standard Toleranz)		Maßstab (Scale)	Rauheit (Roughness)	europ.Projektion	
All informations provided in this drawing is considered to be confidential, proprietary and secret information. It is intended only for the use of individual or entity to whom it is sent. Individual or entity agrees to not disseminate or copy this information to anyone other than originally specified without the written consent Allelectra GmbH.				DIN ISO 2768 f-H		5:1	$\sqrt{Rz 16 (Rz 6.3)}$		
				Material, Standard Oberfläche (Treatment)		Copper Alloy Gold plated		Kanten (edges) $\pm 0,1$ $\pm 0,25$	
				Datum	Name	Bezeichnung (Title)		Gewicht (weight)	
				Design	24.07.2014	JB	Crimp Pin 0.7mm		g
				Drawn	25.07.2014	FW	Female		0.10
				Check	25.07.2014				Page: 1 Pages: 1
						Zeichnungsnummer (Drawing No.)		Revision	
						360-CRF-07			
Index	Modification	Datum	Name	Datei (File)		C:\PDMStore\IC\PDMStore\		Format A4	