

## 622-XY-TILT: X-Y Tilt Stages DN40CF / DN63CF / DN100CF / DN160CF

For precision tilt alignment in two axis, these compact adjustment tools can be used. Large bore and compact design with up to 5° of tilt are the major features of these items.

Both axis can be fixed individually.

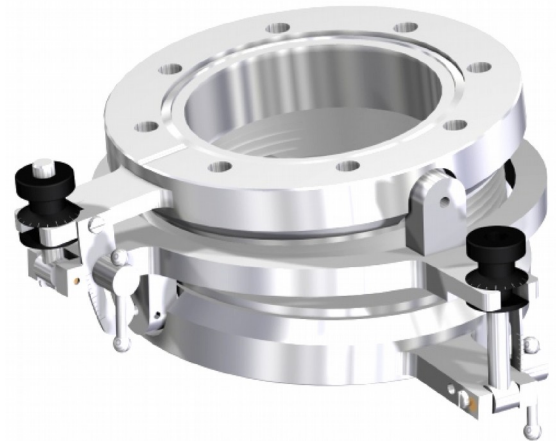

	DN40CF	DN63CF	DN100CF	DN160CF
He leak rate	<math> < 1 \times 10^{-10}</math> mbar l / s He			
Max. Bakeout	230°C			
Max Tilt	+/-5° (both axis)			
Repeatability	<math> < 0.1^\circ</math>			
Flanges	Tapped M6		Tapped M8	
Inner Diameter „ID“	39mm	70mm	102mm	152mm
Outer Radius „R“	40mm	62mm	85mm	112mm
Dim. „A“	64mm	94mm	126mm	156mm
Total height L (not tilt)	39mm	57mm	64mm	66mm

