

REVISION HISTORY			
ISSUE	DESCRIPTION	DATE	APPROVED
A	NEW DRAWING	27/02/2013	

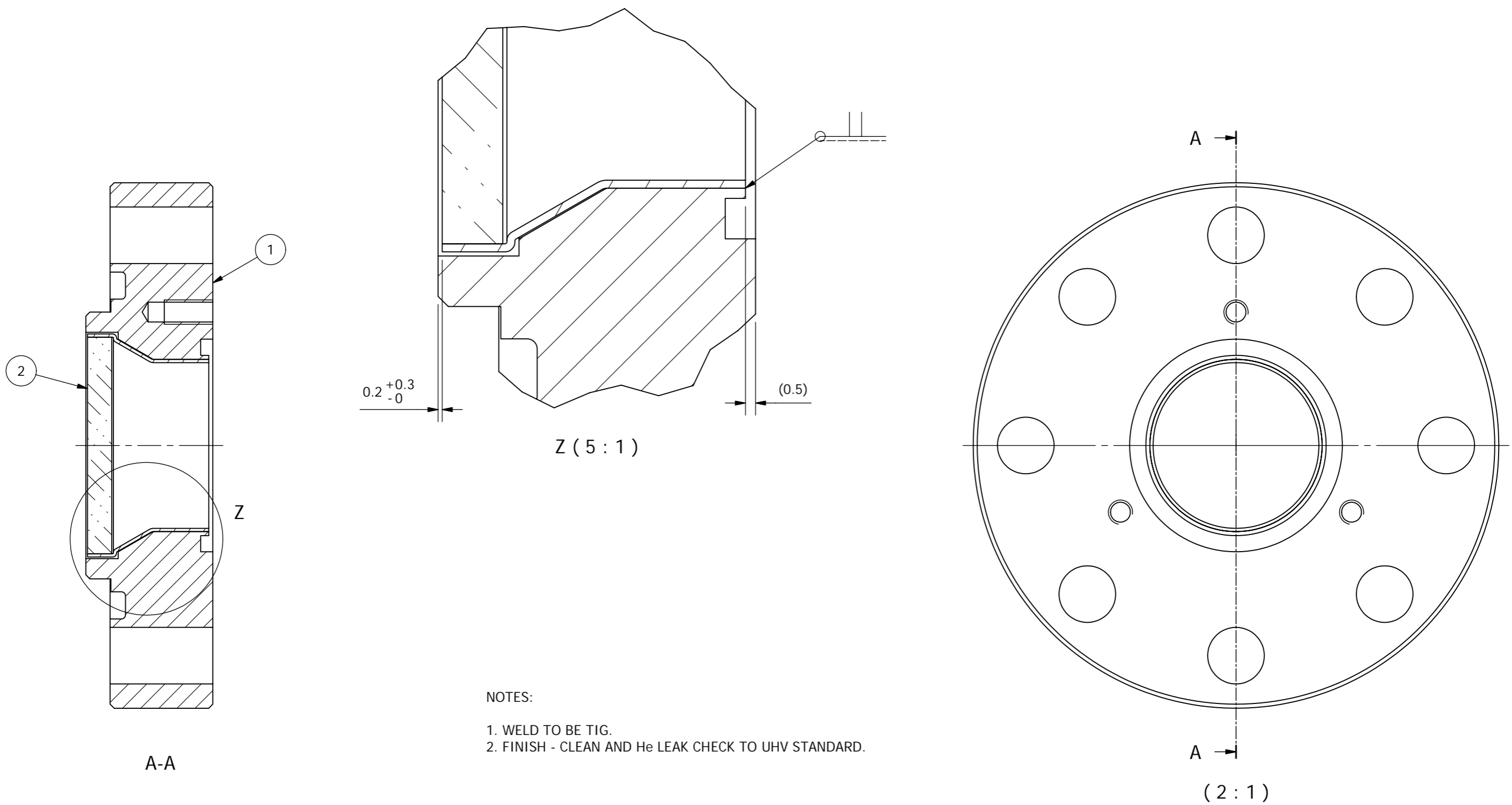

NOTES:
 1. WELD TO BE TIG.
 2. FINISH - CLEAN AND He LEAK CHECK TO UHV STANDARD.

PARTS LIST			
ITEM	PART NUMBER	DESCRIPTION	QTY
1		WINDOW FLANGE M/C DETAIL	1
2		WINDOW	1

Material: SEE PARTS LIST	
Dimensions - mm	 Third Angle Projection
Angular $\pm 0.5^\circ$	
Surface Finish $1.6\mu\text{m}$	
Tolerances - Unless Stated	
Basic Size	Limit
0 - 18	± 0.10
18 - 120	± 0.15
120 - 315	± 0.20
315 - 630	± 0.35
630 - 1000	± 0.50
1000 - 2000	± 1.00

Designed by	Checked by	Approved by	Date	Date
KJP				27/02/2013
ALLECTRA LTD			Edition	Sheet
			A	1 / 1