

REVISION HISTORY			
ISSUE	DESCRIPTION	DATE	APPROVED
A	NEW DRAWING	11/08/2014	

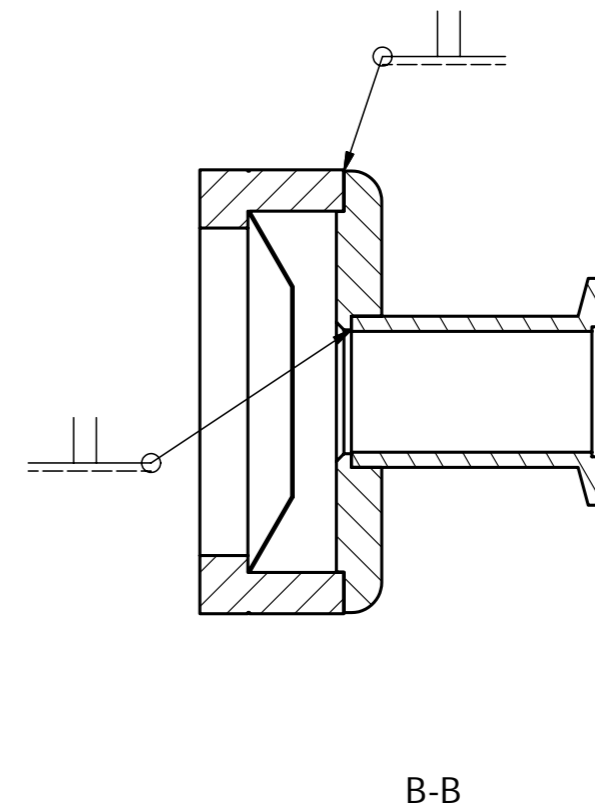
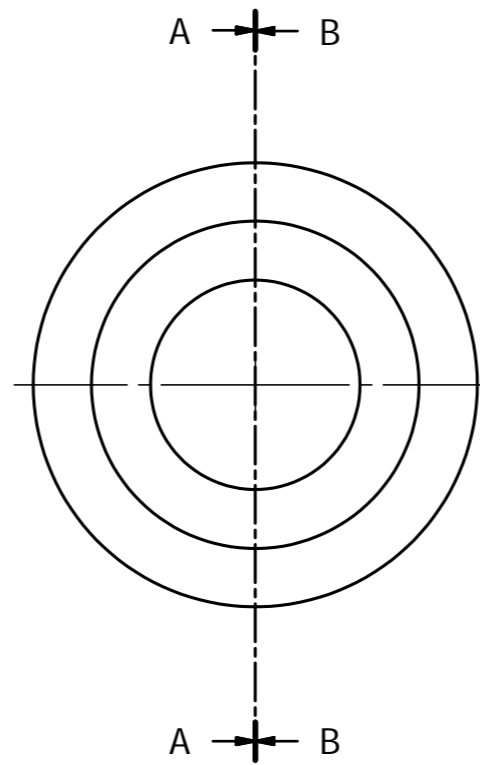
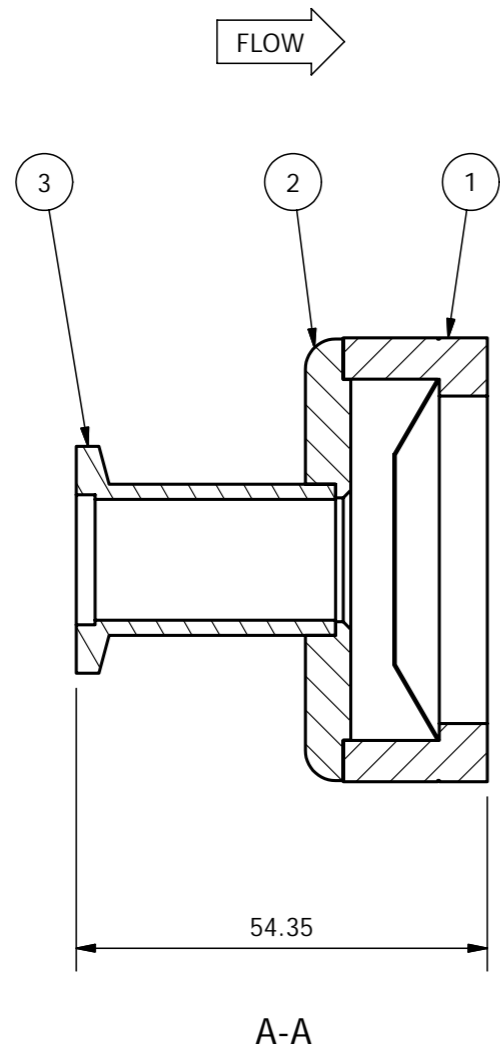

NOTES:

1. ALL WELDS TO BE T.I.G.
2. BURST RANGE: MIN 0.6 BAR
MAX 0.8 BAR ±0.2 BAR
3. FINISH - CLEAN TO UHV STANDARD.
4. LEAK TEST FOR A LEAK RATE LESS THAN 5×10^{-10} mbar l/s He (PULL VACUUM ONLY FROM INLET SIDE).

PARTS LIST

ITEM	PART NUMBER	DESCRIPTION	QTY
1		PRESSURE BURST DISK	1
2	AL-990-4	TUBE/PBD ADAPTOR PLATE	1
3	TU16K30	16KF FLANGE WITH SHORT TUBE	1

Material: SS 316L

Dimensions - mm	 Third Angle Projection
Angular ± 0.5°	
Surface Finish 1.6µm	
Tolerances - Unless Stated	
Basic Size	Limit
0 - 18	± 0.10
18 - 120	± 0.15
120 - 315	± 0.20
315 - 630	± 0.35
630 - 1000	± 0.50
1000 - 2000	± 1.00

Designed by	Checked by	Approved by	Date	File Name	Date
KJP			11/08/2014	al-976.dwg	11/08/2014
ALLECTRA LTD			PRESSURE BURST DISK DN16KF LP		
461-PBD-K16-LP			Edition	Sheet	
			A	1 / 1	